

# INSTRUCTIONS FOR ORDERING PARTS

All service parts should be ordered through your authorized H&S dealer. He will be able to give you faster service if you will provide them with the following:

1. Model & Serial Number - Both can be located on the side of the center bearing post above jack mount.
2. All references to left or right apply to the machine as viewed from the rear.
3. Parts should not be ordered from illustration only. Please order complete part number.
4. If your dealer has to order parts - give shipping instructions:

VIA truck - large pieces (please specify local truck lines)

VIA United Parcel Service (include full address)

H&S MFG. CO. INC.	
MARSHFIELD, WIS.	
MOD. NO.	<input type="text"/>
SER. NO.	<input type="text"/>
DESCR.	<input type="text"/>

PLEASE RECORD NUMBERS FOR YOUR UNIT FOR QUICK REFERENCE

## ABOUT IMPROVEMENTS

H&S IS CONTINUALLY STRIVING TO IMPROVE IT'S PRODUCTS

We must therefore, reserve the right to make improvements or changes whenever it becomes practical to do so, without incurring any obligation to make changes or additions to the equipment previously sold.

FIGURE 1

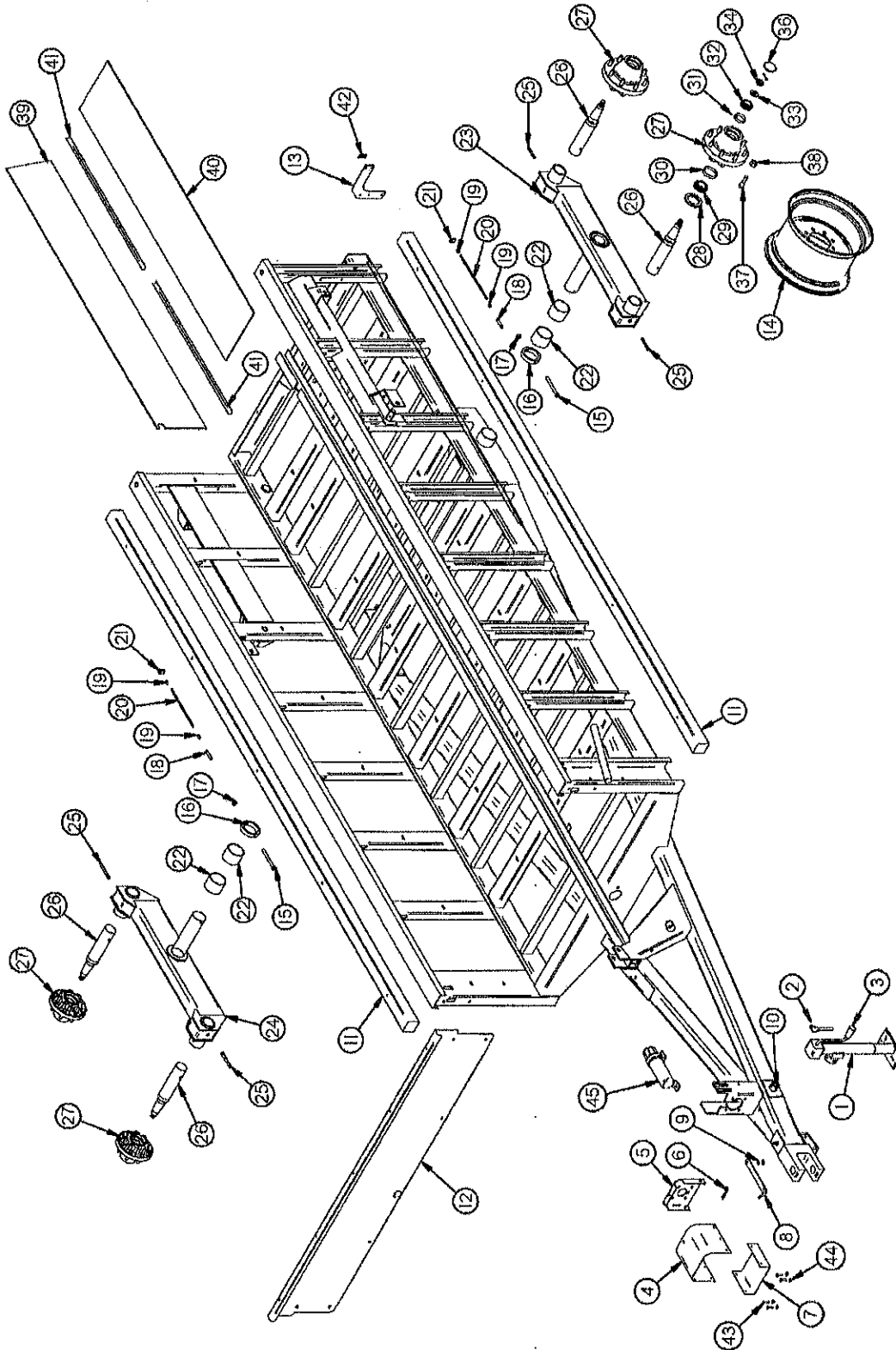
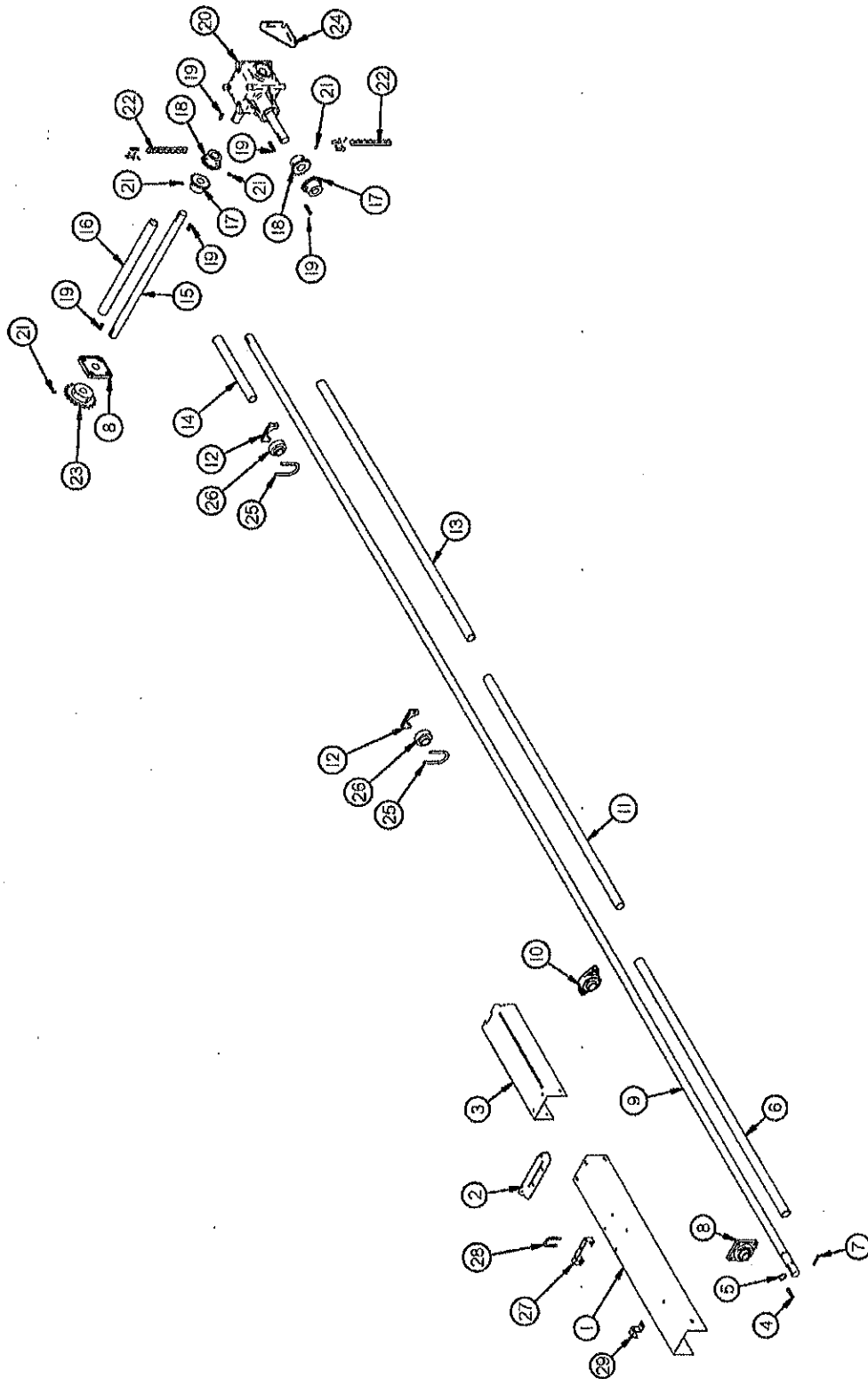

**FIGURE 1**  
**H&S HP425 & HP550 SPREADERS**  
**FRAME ASSEMBLY**

ITEM	HP425	HP550	DESCRIPTION
1.	27N14	"	Jack
2.	12N13	"	Jack Pin & Chain
3.	12N12	"	Jack Handle
4.	16SV329	"	PTO Shield
5.	42N1	"	Shield Mount
6.	X97	"	Hair Pin
7.	16SV327	"	PTO Shield Bottom
8.	42N2	"	PTO Holder
9.	42N3	"	Spring
10.	12N14	"	Jack Mount
11.	42N4	"	Wood Rail
12.	42N5	55N1	Front Panel
13.	42N43	"	SMV Bracket
14.	16SV89	-	Wheel 13.5 x 22.5 (8 Bolt)
*	-	60N15	Wheel 13.5 x 22.5 (10 Bolt)
*	42N138	-	Tire (385 x 22.5 Truck)
*	-	16SV88	Tire (425 x 22.5 Truck)
15.	BFR405	-	1/2" x 5-1/2" Bolt GR. 5
*	-	16SV77	1/2" x 6" Bolt GR. 5
16.	45N35	16SV214	Collar For Axle
17.	9S17	"	1/2" Lock Nut
18.	45N57	"	Grease Line Adapter
19.	S47	"	Grease Fitting
20.	42N41	"	Grease Line
21.	16V9	"	Grease Bracket
22.	45N36	16SV75	Bushing For Tandem Axle
23.	42N6	55N2	Tandem Axle Left
24.	42N7	55N3	Tandem Axle Right
25.	31N4	"	Roll Pin
26.	33SV40	66N15	Spindle
27.	33SV45	60N8	Hub
28.	33SV42	60N5	Seal
29.	33SV43	60N7	Inner Bearing
30.	33SV44	60N6	Inner Race
31.	RG169	60N10	Outer Race
32.	RG170	60N9	Outer Bearing
33.	33SV95	60N2	Washer
34.	RG17	60N3	Spindle Nut
35.	33SV46	60N4	Cotter Pin
36.	RG171	60N11	Hub Cap
37.	33SV41	60N13	Stud
38.	RG72	60N14	Lug Nut
39.	42N8	55N4	Side Poly Right
*	42N9	55N5	Side Poly Left
40.	42N10	"	Floor Poly Right
*	42N11	"	Floor Poly Left
41.	42N12	"	Poly Side Angle
42.	F97	"	SMV Holder
43.	42N97	"	5/16" x 2" Shear Bolt GR.5 (1000 RPM)
*	42N98	-	5/16" x 2" Shear Bolt GR. 8 (540 RPM)
44.	D81	"	Lock Nut
45.	S522	"	Manual Holder

**NOTE: \* (MEANS NOT SHOWN)**  
**- (MEANS NOT USED ON THIS MODEL)**

FIGURE 2



**FIGURE 2**  
**H&S HP425 & HP550 SPREADERS**  
**BEATER DRIVE TRAIN**

ITEM	HP425	HP550	DESCRIPTION
1.	42N13	"	Input Shaft Shield
2.	42N14	"	Input Shield Angle
3.	42N15	"	Input Shield Back
4.	S138	"	3/8" x 2-3/8" Key
5.	12V62	"	Snap Ring
6.	42N16	"	Input PVC Shield
7.	16SV379	"	3/8" x 2-1/2" Roll Pin
8.	12V67	"	Bearing
9.	42N17	"	Input Shaft
10.	42N18	"	Bearing
11.	42N19	"	Drive Shaft Center PVC Shield
12.	42N137	"	Bearing Saddle
13.	42N20	"	Drive Shaft Middle PVC Shield
14.	42N21	"	Drive Shaft Back PVC Shield
15.	42N22	"	Cross Shaft
16.	42N23	"	Cross Shaft PVC Shield
17.	42N24	"	Sprocket 50-B-20 1-1/2" Bore
18.	42N25	"	Sprocket 50-B-20 1-3/4" Bore
19.	PB136	"	3/8" x 2" Key
20.	42N26	"	Gearbox
21.	G83	"	Set Screw
22.	HGV124	"	Connector Chain #50 x 20 Pitches
23.	12V104	"	20 T Sprocket
24.	42N49	"	Gearbox Gusset
25.	42N99	"	3/8" U-Bolt
26.	42N100	"	Bearing
27.	42N101	"	Hose Holder
28.	42N102	"	5/16" x 2" ID U-Bolt
29.	HE14	-	Small Pipe Bracket

**NOTE: " (MEANS SAME AS PREVIOUS PART NO.)**

**- (MEANS NOT USED ON THIS MODEL)**

FIGURE 4

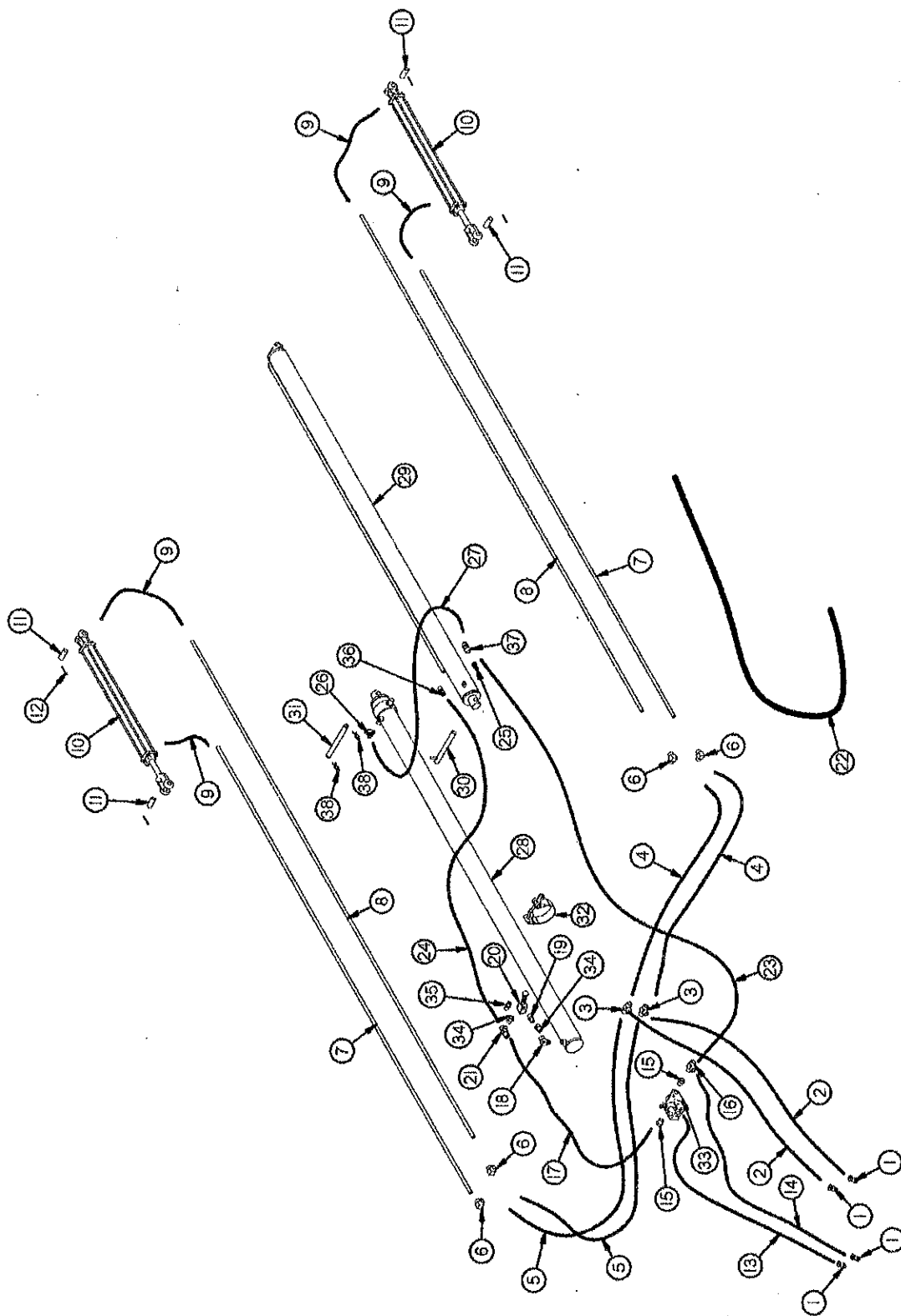

**FIGURE 4**  
**H&S HP425 & HP550 SPREADERS**  
**HYDRAULICS**

ITEM	HP425	HP550	DESCRIPTION
1.	DWM205	"	Quick Coupler Male
2.	12SV25	-	Hydraulic Hose 3/8" x 145" (1/2"MPX x 3/8"MPX)
*	-	55N82	Hydraulic Hose 3/8" x 155" (1/2"MP x 3/8"MP)
3.	BFR74	"	3/8" Tee
4.	46N40	"	Hydraulic Hose 3/8" x 46" (3/8"MPX x 3/8"MP)
5.	BFR287	"	Hydraulic Hose 3/8" x 36" (3/8"MPX x 3/8"MP)
6.	HE59	"	3/8" Elbow
7.	42N59	55N23	End Gate Hydraulic Line Short
8.	42N60	55N24	End Gate Hydraulic Line Long
9.	12V19	"	Hydraulic Hose 3/8" x 24" (3/8"FP x 3/8"MPX)
10.	45N45	"	Hydraulic Cylinder (2" x 20")
11.	56N141	"	Cylinder Pin
12.	23N108	"	7/32" x 2" Cotter Pin
13.	42N61	-	Hydraulic Hose 3/8" x 93" (1/2"MP x 1/2"MP)
*	-	55N6	Hydraulic Hose 1/2" x 93" (1/2"MP x 1/2"MP)
14.	42N62	-	Hydraulic Hose 3/8" x 95" (3/8"MP x 1/2"MP)
*	-	55N7	Hydraulic Hose 1/2" x 95" (1/2"MP x 1/2"MP)
15.	JB82	-	1/2" x 3/8" Bushing
16.	23N116	-	3/8" Service Tee
*	-	LW96	1/2" Service Tee
17.	42N63	-	Hydraulic Hose 3/8" x 82" (3/8"MPX x 3/8"MPX 90°)
*	-	55N8	Hydraulic Hose 1/2" x 82" (1/2"MPX x 1/2"MPX 90°)
18.	23N234	-	3/8" Street Elbow
*	-	HE58	1/2" Street Elbow
19.	16SV351	"	3/8" Nipple Nut
20.	16SV339	"	Sequence Valve
21.	WM146	-	3/8" Male, Female Tee
*	-	DF8	1/2" Tee
22.	42N64	"	Hose Shield (1-1/2"ID x 73")
23.	42N65	-	Hydraulic Hose 3/8" x 158" (3/8"MPX 90° x 3/8"MPX)
*	-	55N29	Hydraulic Hose 1/2" x 158" (1/2"MPX 90° x 1/2"MPX)
24.	42N66	-	Hydraulic Hose 3/8" x 76" (3/8"MP x 3/8"MP)
*	-	55N30	Hydraulic Hose 1/2" x 76" (1/2"MP x 1/2"MP)
25.	42N67	-	3/8" Union Adapter 45°
*	-	55N65	1/2" Union Adapter 45°
26.	DWM110	-	3/8" Union Adapter 90°
*	-	HE58	1/2" Street Elbow
27.	42N68	-	Hydraulic Hose 3/8"x20-1/2" (3/8"MP x 3/8"MPX 90°)
*	-	16SV143	Hydraulic Hose 1/2" x 19" (1/2"MP x 1/2"MPX)
28.	42N69	-	Hydraulic Cylinder 3-1/2" x 90" Gimbal Mount
*	-	55N32	Hydraulic Cylinder 4-1/2" x 90" Gimbal Mount
29.	42N70	-	Hydraulic Cylinder 3-1/2" x 90" Trunnion Mount
*	-	55N33	Hydraulic Cylinder 4-1/2" x 90" Trunnion Mount
30.	42N71	55N34	Cylinder Pin
31.	42N72	55N35	Pusher Cylinder Pin
32.	12V70	-	Hose Clamp SAE#88
*	-	55N66	Hose Clamp SAE#104
33.	42N73	"	Flow Control
34.	-	JB82	1/2" To 3/8" Bushing
35.	-	16SV351	3/8" Nipple Nut
36.	DWM233	-	3/8" Union Adapter
*	-	55N70	1/2" Union Adapter
37.	23N116	-	3/8" Service Tee
*	-	WM139	1/2" Male-Female Tee
38.	T144	"	Cylinder Clip Pin

NOTE: \*(MEANS NOT SHOWN)

- (MEANS NOT USED ON THIS MODEL)

" (MEANS SAME AS PREVIOUS PART NO.)

**FIGURE 5**

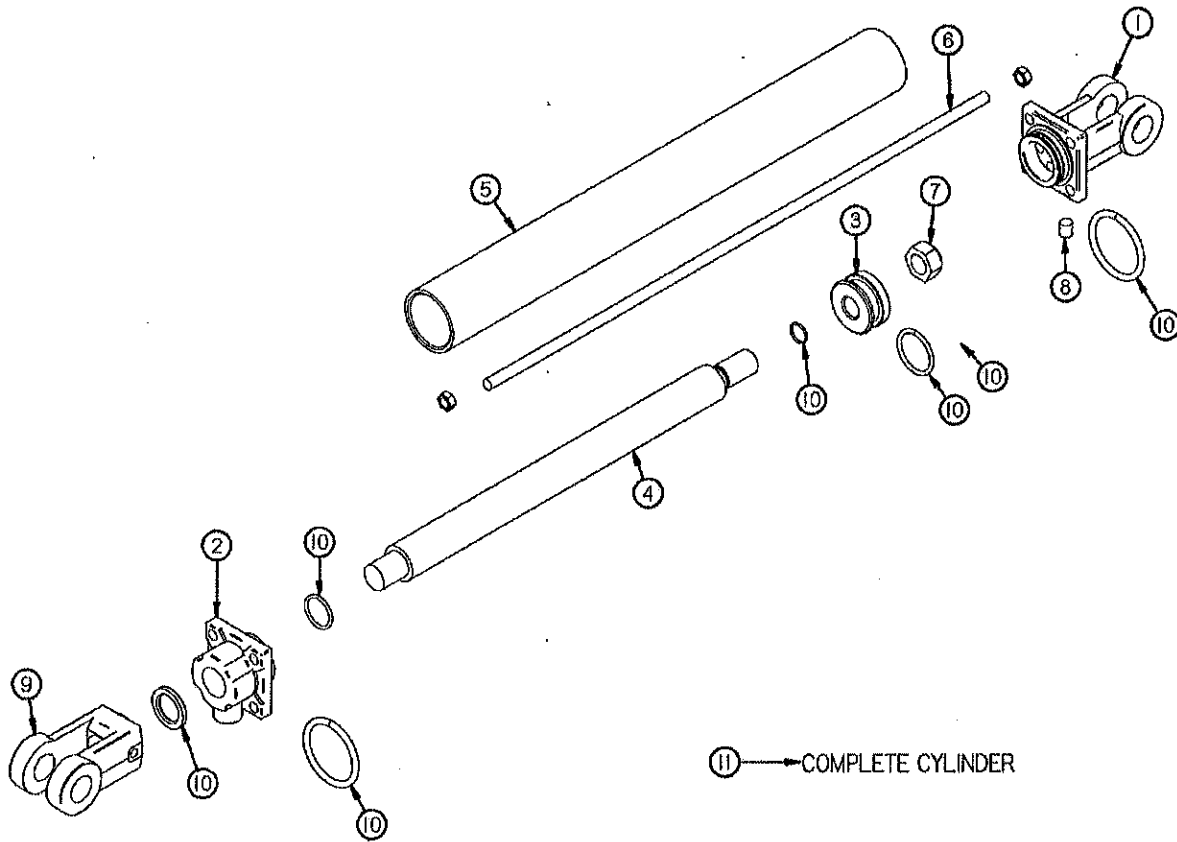

**FIGURE 5  
H&S HP425 & HP550 SPREADERS  
HYDRAULIC END GATE CYLINDER**

ITEM	HP425	HP550	DESCRIPTION
1.	23N142A	"	Clevis Cap
2.	23N143A	"	Rod Cap
3.	23N144	"	Piston
4.	45N42	"	Rod
5.	45N43	"	Cylinder Tube
6.	45N44	"	Tie Rod
7.	23N148	"	Piston Nut
8.	23N149	"	Plug
9.	23N150A	"	Rod Clevis
10.	23N151	"	Seal Kit
11	45N45	"	Hydraulic Cylinder



FIGURE 6

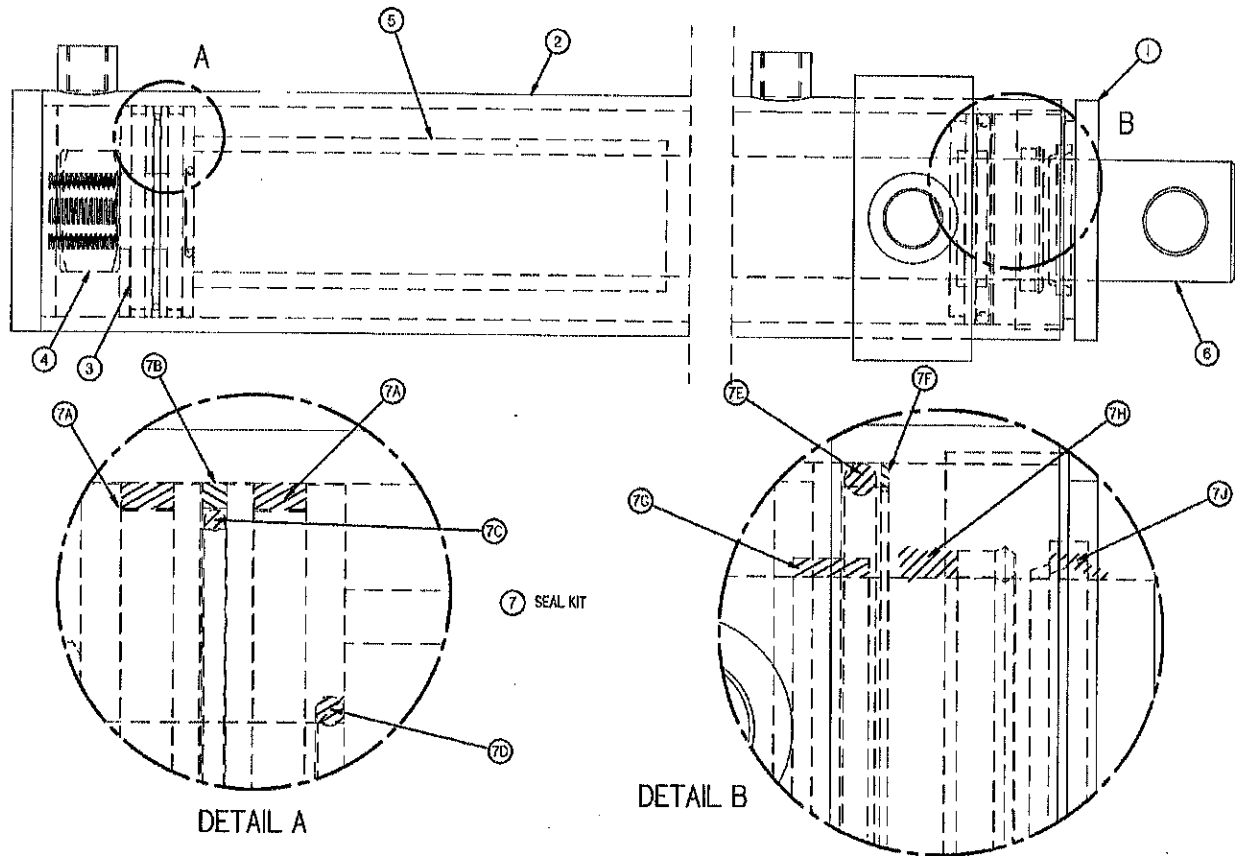

FIGURE 6  
H&S HP425 & HP550 SPREADERS  
HYDRAULIC PUSHER CYLINDER

ITEM	HP425	HP550	DESCRIPTION
1.	42N106	55N36	Internal Head
2.	42N107	55N37	Barrel Assembly (Top Cylinder)
*	42N108	55N38	Barrel Assembly (Bottom Cylinder)
3.	42N109	55N39	Piston
4.	42N110	55N40	Lock Nut
5.	42N111	55N41	Spacer
6.	42N112	55N42	Rod
7.	42N113	55N43	Seal Kit
7A.	"	"	Wear Ring
7B.	"	"	Poly Hone
7C.	"	"	O-Ring
7D.	"	"	O-Ring
7E.	"	"	O-Ring
7F.	"	"	Back-up Ring
7G.	"	"	Wear Ring
7H.	"	"	Loaded U-Cup
7J.	"	"	Rod Wiper
*	42N69	55N32	Complete Cylinder (Top)
*	42N70	55N33	Complete Cylinder (Bottom)

NOTE: \* (MEANS NOT SHOWN)

" (PART NOT SOLD SEPRATELY ONLY COMPLETE KIT)

FIGURE 7

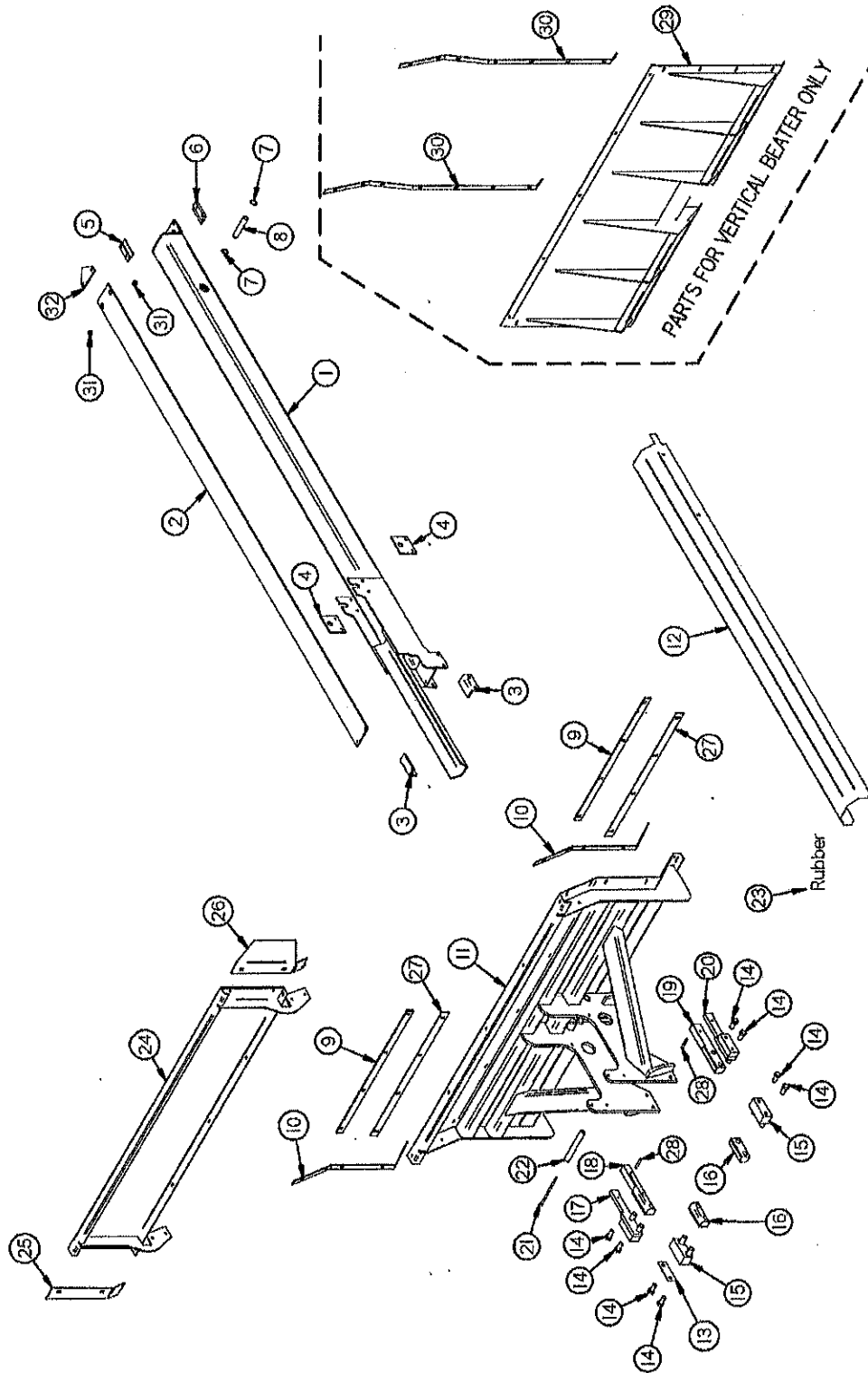

**FIGURE 7**  
**H&S HP425 & HP550 SPREADERS**  
**PUSHER**

ITEM	HP425	HP550	DESCRIPTION
1.	42N74	55N44	Moveable Floor Tube
2.	42N75	55N45	Pusher Tubing Slide
3.	42N76	55N46	Pusher Tube Front Guide
4.	42N77	55N47	Cylinder Retainer
5.	42N78	55N48	End Cap Clamp Right
6.	42N79	55N49	End Cap Clamp Left
7.	3G21	-	1" Snap Ring
*	-	F73	1-1/4" Snap Ring
8.	42N80	55N50	Rear Cylinder Pin
9.	42N81	55N81	Pusher Wiper
10.	42N82	55N25	Pusher Rubber Strap (Horizontal Beater Only)
11.	42N83	55N26	Pusher
12.	42N84	55N51	Cylinder Shield
13.	42N114	-	Pusher Shim (As Required)
14.	50N183	"	5/8" x 1-1/4" Bolt GR. 5
15.	42N85	55N52	Poly Block Spacer
16.	42N86	55N53	Pusher Poly Slide
17.	42N87	55N54	Poly Block Spacer Right
18.	42N88	55N55	Pusher Poly Slide Right
19.	42N89	55N56	Pusher Poly Slide Left
20.	42N90	55N57	Poly Block Spacer Left
21.	A7	-	1/2" x 9-1/2" Bolt GR. 5
*	-	55N58	1/2" x 10-1/2" Bolt GR. 5
22.	42N91	55N59	Pusher Spacer
23.	42N92	55N27	Pusher Rubber Left
*	42N93	55N28	Pusher Rubber Right
24.	42N94	"	Pusher Extension
25.	42N95	"	Extension Wing Right
26.	42N96	"	Extension Wing Left
27.	42N139	55N83	Pusher Bottom Rubber
28.	42N140	16SV379	3/8" Expansion Pin
29.	HGV115	HGV113	Flat Pusher Face
30.	HGV116	HGV114	Flat Pusher Seal Strap
31.	42N150	"	Poly Spacer
32.	42N151	55N86	Scraper

**NOTE: \* (MEANS NOT SHOWN)**

**- (MEANS NOT USED ON THIS MODEL)**

FIGURE 8

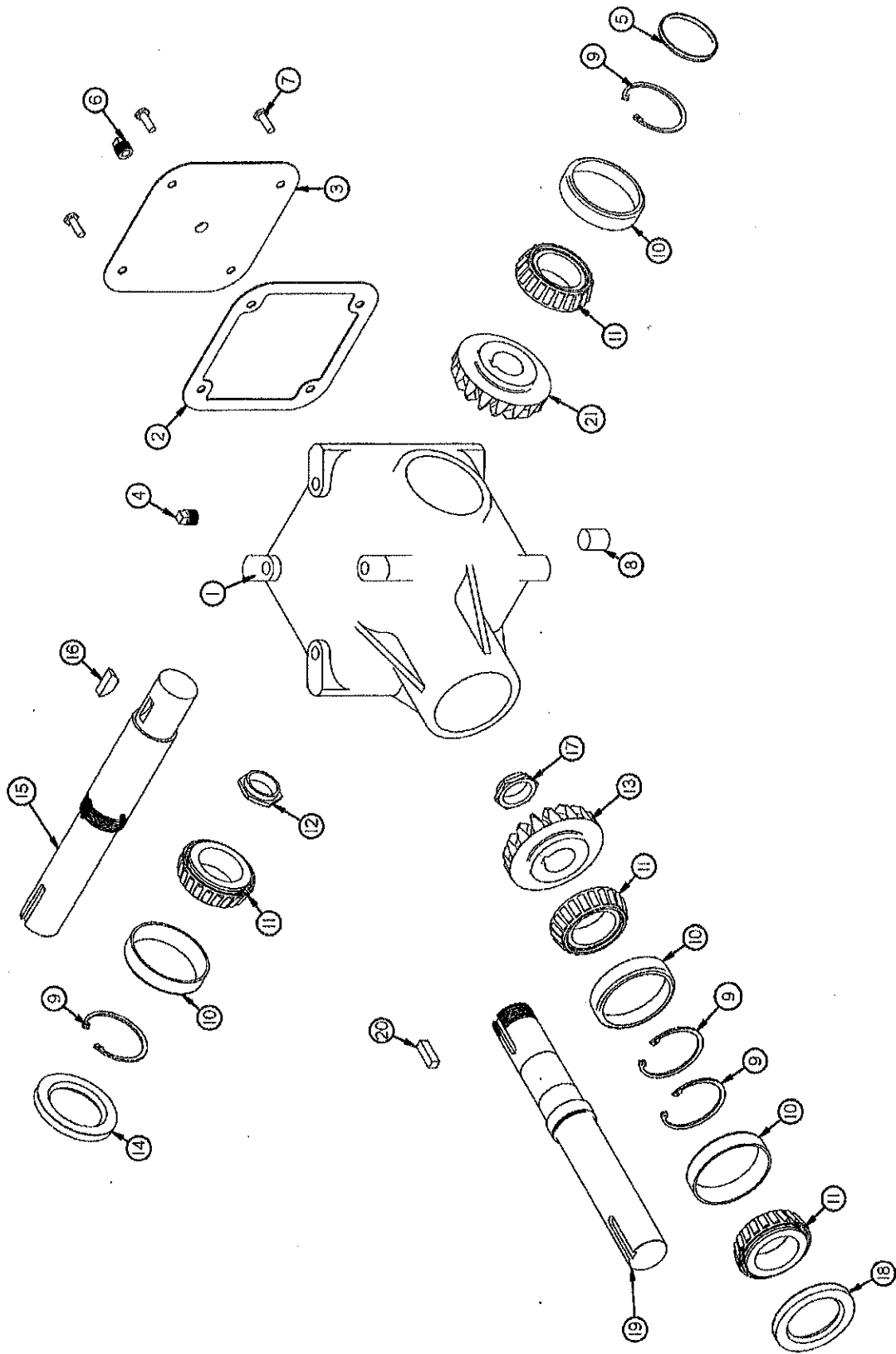

**FIGURE 8  
H&S HP425 & HP550 SPREADERS  
BEATER GEAR BOX**

ITEM	HP425	HP550	DESCRIPTION
1.	G125	"	Housing
2.	G138	"	Gasket
3.	G126	"	Cover
4.	G144	"	3/8" Vent Plug
5.	G140	"	Cap
6.	G65	"	3/8" Plug - NPT
7.	G56	"	5/16" x 5/8" Cap Screw
8.	G145	"	3/8" Plug
9.	G130	"	Snap Ring
10.	G128	"	Bearing Cup #25520
11.	G129	"	Bearing #25581
12.	G132	"	Stake Nut
13.	G142	"	Bevel Gear 22 Teeth
14.	G136	"	Seal - Output
15.	42N57	"	Output Shaft
16.	G61	"	"E" 1210 Woodruff Key
17.	G133	"	Stake Nut
18.	G137	"	Seal - Input
19.	42N58	"	Input Shaft
20.	G139	"	3/8" x 1-1/2" Hardened Key
21.	G127	"	Bevel Gear 33 Teeth
*	42N26	"	Complete Gear Box

**NOTE \* (MEANS NOT SHOWN)**

**- (MEANS SAME AS PREVIOUS PART NO.)**

FIGURE 9

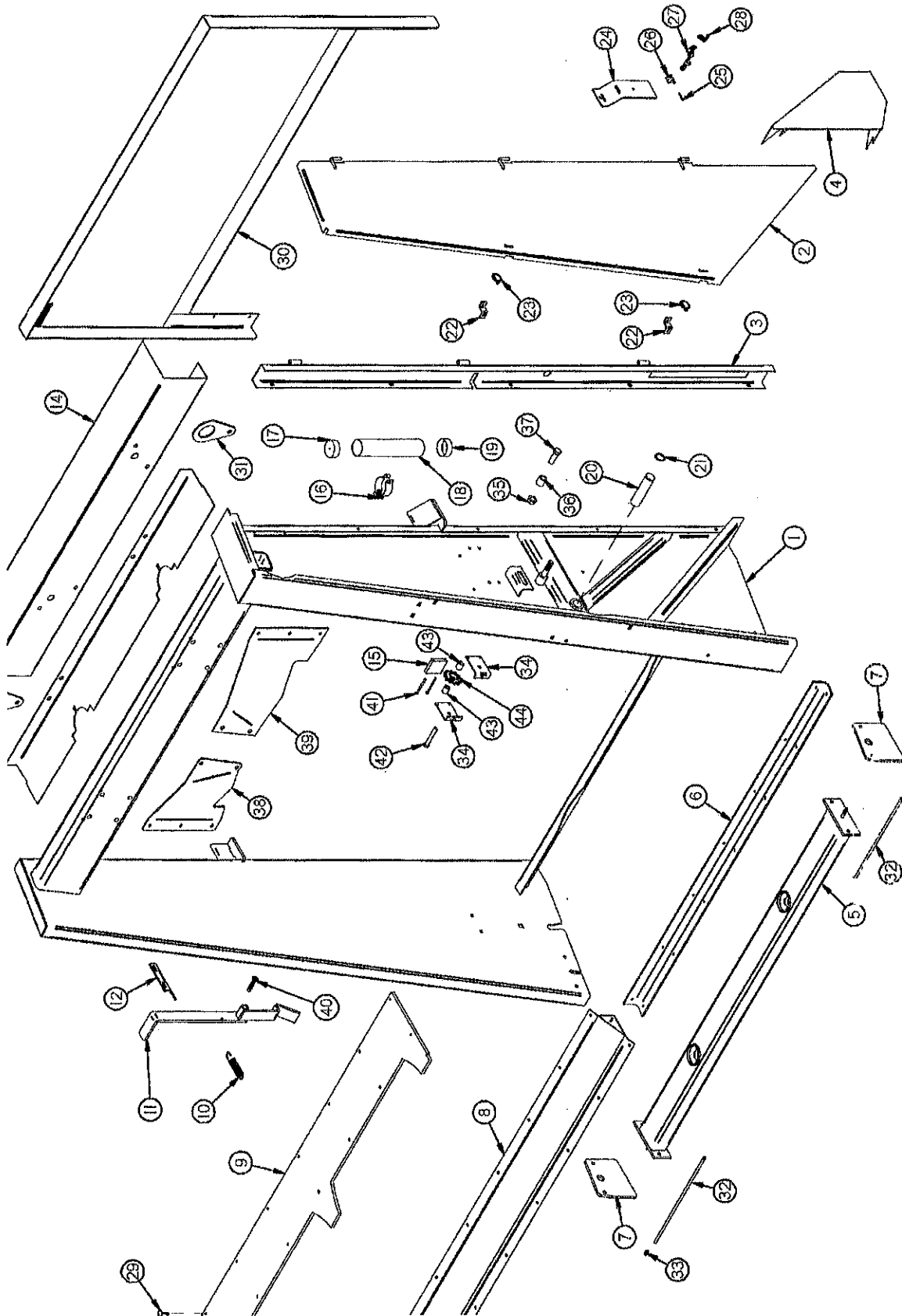
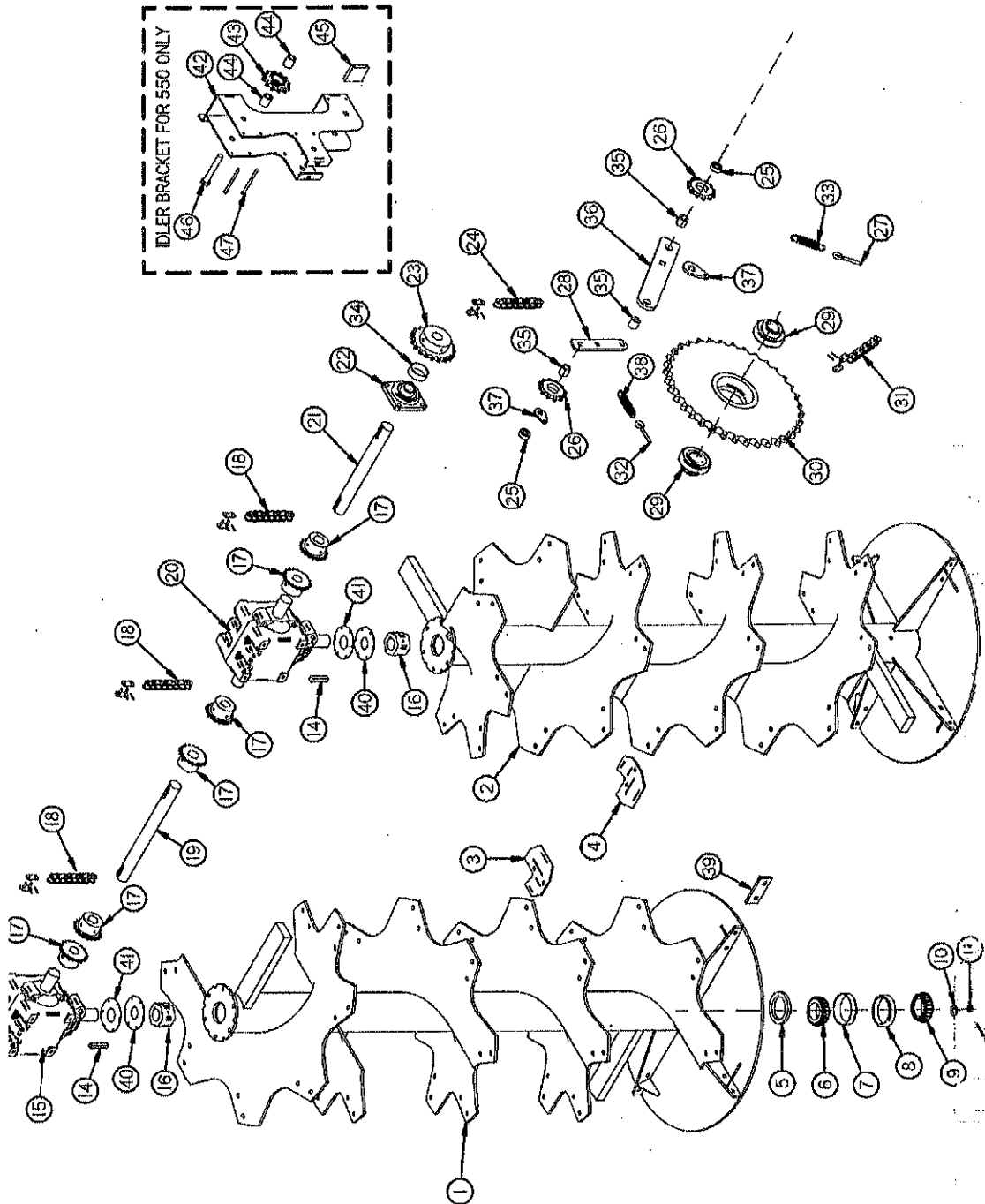

**FIGURE 9**  
**H&S HP425VB & HP550VB SPREADERS**  
**VERTICAL BEATERS FRAME ASSEMBLY**

<u>ITEM</u>	<u>HP425VB</u>	<u>HP550VB</u>	<u>DESCRIPTION</u>
1.	HGV54	HGV55	Frame
2.	HGV3	HGV4	Rear Shield
3.	HGV5	HGV6	Shield Filler
4.	HGV7	"	Cross Shaft Shield
5.	HGV8	"	Beater Bottom Mount
6.	HGV9	"	Pan Hinge
7.	HGV10	"	Leg
8.	HGV11	"	Pan Bottom
9.	HGV12	"	Pan
10.	K103	"	Spring
11.	HGV13	"	Pan Handle
12.	HGV14	"	Pan Handle Stop
13.	HGV56	"	Gearbox Bottom Shield (Superior)
*	HGV15	"	Gearbox Bottom Shield (Durst)
14.	HGV57	"	Gearbox Top Shield (Superior)
*	HGV16	"	Gearbox Top Shield (Durst)
15.	HGV109	--	Chain Poly Block
16.	S416	"	Manual Holder Clamp
17.	S414	"	Cap
18.	S415	"	Manual Holder Tube
19.	S418	"	Cap w/Hole
20.	HGV18	"	Sprocket Idler Shaft
21.	12V62	"	Snap Ring
22.	F69	"	Shield Bracket
23.	F56	"	Clip Pin
24.	42N105	"	Back Stake Filler
25.	X195	"	Pin
26.	X194	"	Latch Mounting Bracket
27.	X192	"	Latch (Rubber)
28.	X193	"	Latch Catch Bracket
29.	HGV48	"	5/16" x 1-1/2" Step Bolt
30.	HGV49	"	Stone Guard
31.	HGV50	"	Lifting Eye
32.	HGV51	"	Grease Line
33.	HGV52	"	Grease Fitting
34.	HGV100	--	Idler Bracket
35.	16SV64	"	3/4" Flange Nut
36.	16SV44	"	Tightener Spacer
37.	HE8	"	3/4" x 2-1/4" Bolt GR.5
38.	-	HGV107	Main Panel Brace Left
39.	-	HGV106	Main Panel Brace Right
40.	HGV108	"	Latch Pivot Bolt (3/4" X 3-1/2" Carriage Gr. 5)
41.	G70	--	5/16" X 4-1/2" Gr. 5 Bolt
42.	HD87	--	3/4" X 5" Gr. 5 Bolt
43.	HGV111	--	Sprocket Spacer
44.	16SV328	--	Sprocket 80-C-12 w/Bearing
*	HGV117	--	Complete Idler Assembly

**NOTE: \* (MEANS NOT SHOWN)**  
**" (MEANS SAME AS PREVIOUS MODEL)**  
**--(MEANS NOT USED ON THIS MODEL)**

FIGURE 10



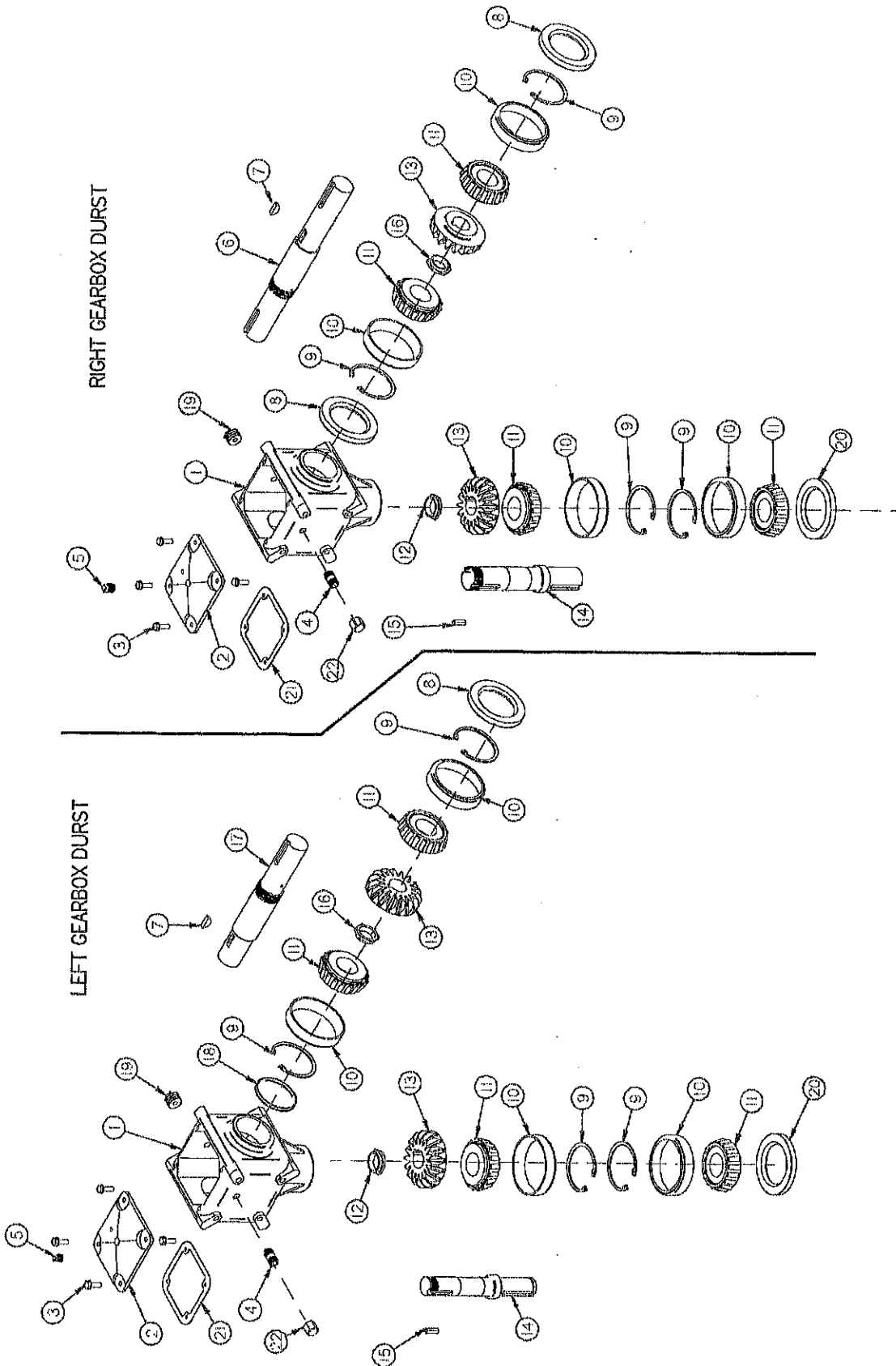

**FIGURE 10**  
**H&S HP425VB & HP550VB SPREADERS**  
**VERTICAL BEATERS DRIVE TRAIN**

ITEM	HP425VB	HP550VB	DESCRIPTION
1.	HGV118	HGV119	Beater Left Hand
2.	HGV120	HGV121	Beater Right Hand
3.	HGV122	"	Beater Blade Left
4.	HGV123	"	Beater Blade Right
5.	HGV27	"	Seal
6.	B5	"	Bearing Cone
7.	B5A	"	Bearing Cup
8.	3G18	"	Bearing Cup
9.	3G7	"	Bearing Cone
10.	BFR63	"	Washer
11.	BFR64	"	Nut
12.	BFR65	"	Cotter Pin
13.	17G144	"	Hub Cap
14.	S38	"	3/8" x 2-3/8" Square Key
15.	HGV58	"	Gearbox Left (Superior)
*	HGV28	"	Gearbox Left (Durst)
16.	26VB37	"	Gearbox Connector
17.	42N25	"	Sprocket 50-B-20 1-3/4" Bore
18.	HGV124	"	Connector Chain #50 x 20 Pitches
*	D118	"	Connector Link #50
19.	HGV59	"	Gearbox Cross Shaft (Superior)
*	HGV31	"	Gearbox Cross Shaft (Durst)
20.	HGV60	"	Gearbox Right (Superior)
*	HGV32	"	Gearbox Right (Durst)
21.	HGV61	"	Gearbox Drive Shaft (Superior)
*	HGV33	"	Gearbox Drive Shaft (Durst)
22.	HGV41	"	Bearing
23.	HGV25	"	Sprocket 80-B-20 1-3/4" Bore
24.	--	HGV125	Gearbox Chain #80 x 138 Pitches
*	HGV35	-	Gearbox Chain #80 x 97 Pitches
*	F157	"	Connector Link #80
25.	12V52	"	Bearing
26.	12V77	"	Idler Sprocket w/Bearing (80-A-12)
27.	BFR374	"	I-Bolt 3/8" x 3"
28.	HGV36	"	Beater Tightener
29.	42N100	"	Bearing
30.	-	HGV37	Sprocket 80-A-36 to 80-A-20
*	HGV38	-	Sprocket 80-A-20 to 80-A-20
31.	-	HGV127	Drive Chain #80 x 117 Pitches
*	HGV40	-	Drive Chain #80 x 109 Pitches
*	F157	"	Connector Link #80
32.	HGV46	"	I-Bolt 5/16" x 1"
33.	10R14	"	Spring
34.	HGV30	"	Spacer
35.	HGV43	"	Spacer
36.	HGV42	"	Tightener
37.	56N160	"	Spring Holder
38.	ST36	"	Spring
39.	26VB57	"	Fan Blade
40.	HGV129	"	Beater Rubber Seal
41.	HGV130	"	Beater Seal Cap
42.	--	HGV131	Idler Bracket
43.	--	16SV328	Sprocket 80-C-12 W/Bearing
44.	--	HGV111	Sprocket Spacer
45.	--	HV109	Chain Poly Block
46.	--	HD87	3/4" X 5" Gr. 5 Bolt
47.	--	G70	5/46" X 4-1/2" Br. 5 Bolt

**NOTE: \* (MEANS NOT SHOWN)**  
**" (MEANS SAME AS PREVIOUS MODEL)**  
**- (MEANS NOT USED ON THIS MODEL)**

FIGURE 11



**FIGURE 11**  
**H&S HP425VB & HP550VB SPREADERS**  
**VERTICAL BEATERS BEVEL GEARBOX**

<b>ITEM</b>	<b>HP425VB</b>	<b>HP550VB</b>	<b>DESCRIPTION</b>
1.	G125	"	Gearbox Housing
2.	G126	"	Cover
3.	G56	"	Capscrew
4.	23N288	"	Close Nipple
5.	G65	"	Plug 3/8" NPT
6.	HGV26	"	Input Shaft
7.	G61	"	Woodruff Key (Hard "E" 1210)
8.	G136	"	Seal
9.	G130	"	Snap Ring
*	G141	"	Shim
10.	G128	"	Bearing Cup #14276
11.	G129	"	Bearing Cone #14137A
12.	G133	"	Stake Nut 1-3/4"
13.	G147	"	Bevel Gear
14.	HGV44	"	Output Shaft
15.	G139	"	Key 3/8" Square x 1-3/8" Hardened
16.	G132	"	Stake Nut 2"
17.	HGV45	"	Input Shaft
18.	G140	"	Cap
19.	LW298	"	Plug 3/8" -18 NPTF
20.	G136	"	Seal
21.	G138	"	Gasket
*	HGV28	"	Gearbox Left Complete (Durst)
*	HGV32	"	Gearbox Right Complete (Durst)

**NOTE: \* (MEANS SOT SHOWN)**

**" (MEANS SAME AS PREVIOUS MODEL)**

**FIGURE 12**

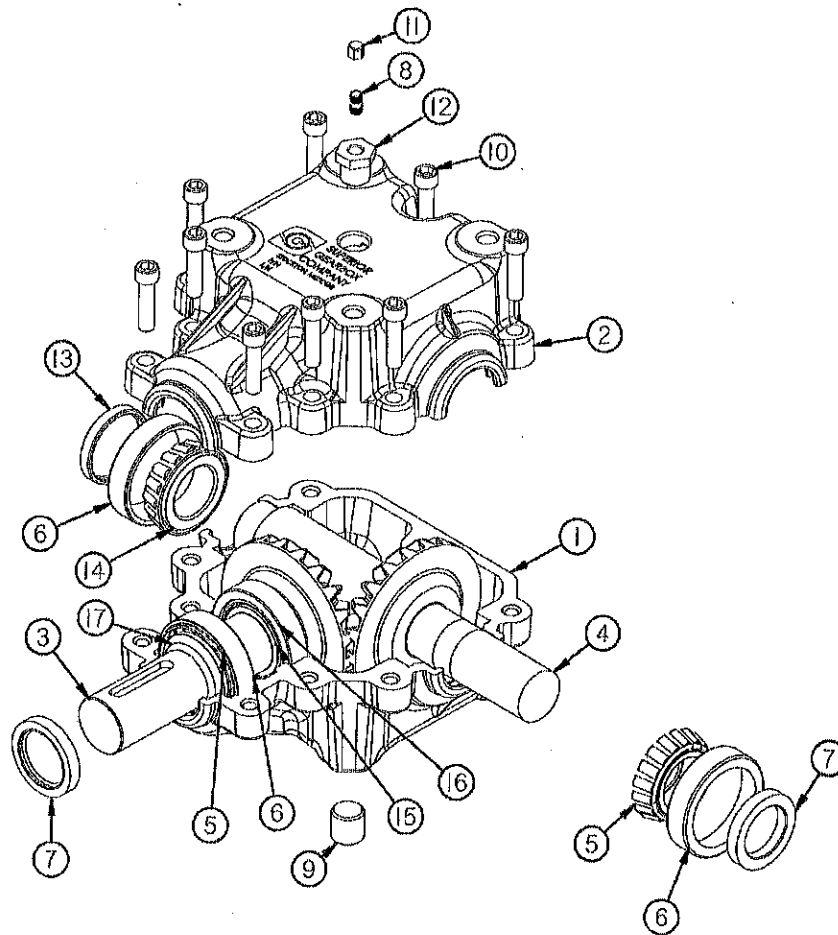

**Figure 12  
SUPERIOR GEARBOX LEFT**

<b>ITEM</b>	<b>425</b>	<b>550</b>	<b>DESCRIPTION</b>
1.	HGV88	"	Bottom Housing
2.	HGV89	"	Top Housing
3.	HGV90	"	Output Shaft
4.	HGV105	"	Input Shaft
5.	HGV91	"	Bearing Cone (625581)
6.	HGV92	"	Bearing Cup (625520)
7.	HGV93	"	Seal (617285)
8.	23N288	"	3/8" Nipple
9.	HGV95	"	Plug (1/2-14 NPT)
10.	HGV96	"	Gearbox Bolt (3/8-16 X 2-1/4")
11.	17G58	"	Vent
12.	JB82	"	Bushing (1/2 NPT - To - 3/8NPT)
13.	HGV99	"	Cap
14.	HGV94	"	Bearing Cone (625580)
15.	HGV97	"	Bearing Cone (603782)
16.	HGV112	"	Bearing Cup (603720)
17.	HGV98	"	Retaining Ring (603493)
*	HGV58	"	Complete Gearbox Left

**FIGURE 13**

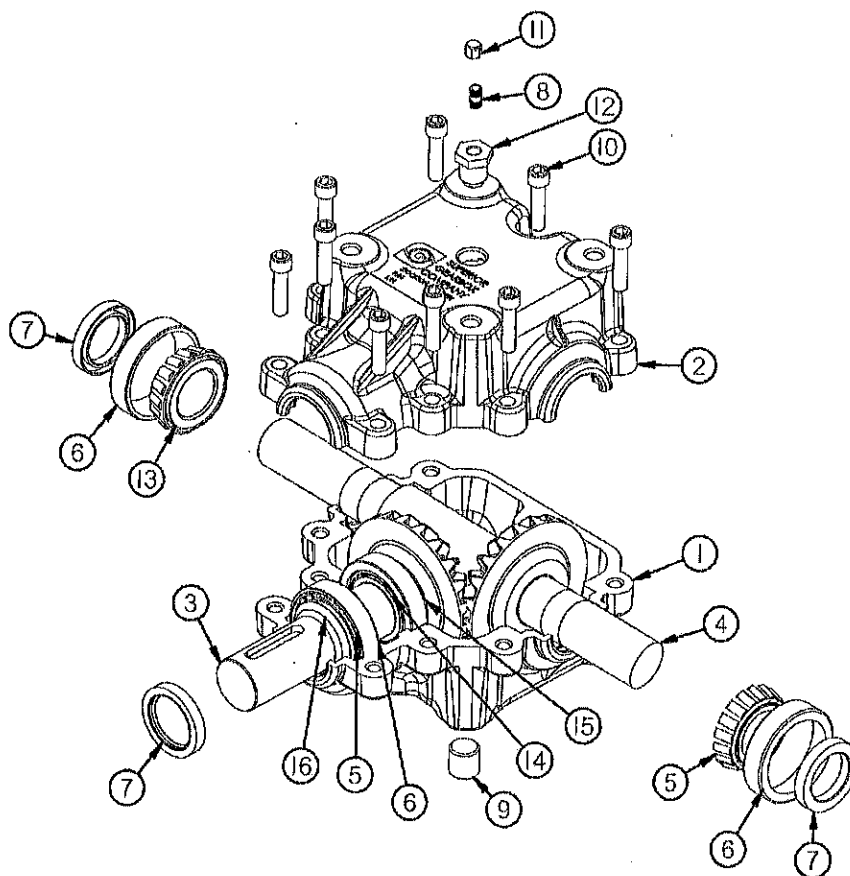

**FIGURE 13  
SUPERIOR GEARBOX RIGHT**

<u>ITEM</u>	<u>425</u>	<u>550</u>	<u>DESCRIPTION</u>
1.	HGV88	"	Bottom Housing
2.	HGV89	"	Top Housing
3.	HGV90	"	Output Shaft
4.	HGV101	"	Input Shaft
5.	HGV91	"	Bearing Cone (625581)
6.	HGV92	"	Bearing Cup (625520)
7.	HGV93	"	Seal (617285)
8.	23N288	"	3/8" Nipple
9.	HGV95	"	Plug (1/2-14 NPT)
10.	HGV96	"	Gearbox Bolt (3/8-16 X 2-1/4")
11.	17G58	"	Vent
12.	JB82	"	Bushing (1/2 NPT -To-3/8 NPT)
13.	HGV94	"	Bearing Cone (625580)
14.	HGV97	"	Bearing Cone (603782)
15.	HGV112	"	Bearing Cup (603720)
16.	HGV98	"	Retaining Ring (603493)
*	HGV60	"	Complete Gearbox Right

FIGURE 14

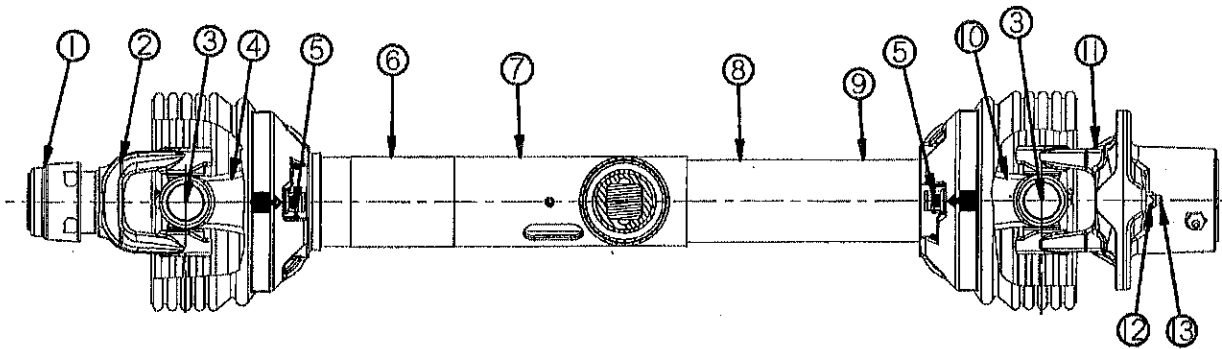

FIGURE 14  
H&S HP425 & HP550 SPREADERS  
PTO & OVERRUNNING CLUTCH

ITEM	540 RPM	1000 RPM 1-3/8"	1000 RPM 1-3/4"	DESCRIPTION
1.	16SV274	"	16SV275	Auto-Lock Repair Kit
2.	42N115	55N68	55N69	Auto-Lock Yoke Assembly
3.	16SV179	"	"	35R Cross Bearing Kit
4.	42N116	"	"	Yoke Shaft
5.	16SV181	"	"	Nylon Repair Kit
6.	16SV283	"	"	Safety Sign
7.	42N117	"	"	Outer Guard
8.	42N118	"	"	Inner Guard
9.	16SV286	"	"	Safety Sign
10.	42N119	"	"	Yoke, Tube & Slip Sleeve
11.	42N120	"	"	OR Ball Shear Assembly
12.	16SV193	"	"	5/16"-18 Lock Nut
13.	42N121	-	-	5/16"-18 x 2" Bolt GR. 8 (540 RPM)
*	-	55N71	"	5/16"-18 x 2" Bolt GR. 5 (1000 RPM)
*	42N122	55N72	55N73	Joint & Shaft Half Assembly w/Guard
*	42N123	55N74	55N75	Joint & Shaft Half Assembly
*	42N124	55N76	"	Joint & Tube Half Assembly w/Guard
*	42N125	55N77	"	Joint & Tube Half Assembly
*	42N126	55N78	55N79	Complete PTO
*	S204	"	"	PTO Safety Manual

NOTE: \* (MEANS NOT SHOWN)  
 - (MEANS NOT USED ON THIS MODEL)  
 " (MEANS SAME AS PREVIOUS PART NO.)

FIGURE 15

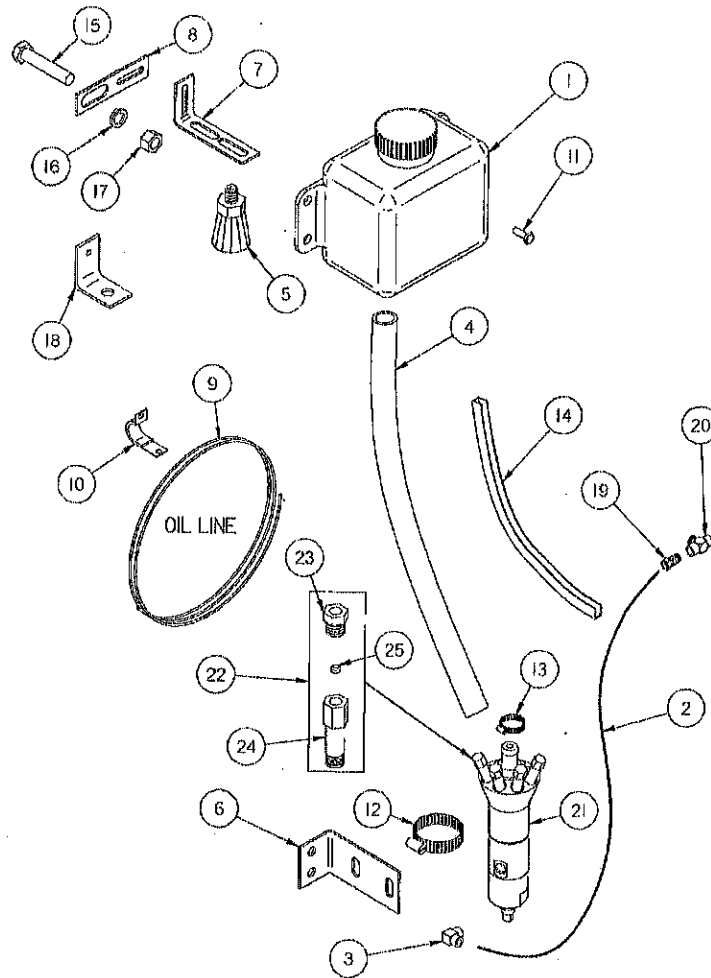

FIGURE 15  
H&S HP425 & HP550 SPREADERS  
CHAIN OILER

ITEM	PART#	DESCRIPTION	ITEM	PART#	DESCRIPTION
1.	HGV63	Reservoir	14.	HGV77	Edging 12"
2.	HGV64	Hydraulic Hose 1/4" x 80"	*	HGV78	Large Tube Holder
3.	HGV65	O-Ring/JIC Elbow	15.	HGV79	9/16" x 2-1/2" Bolt GR. 5
4.	HGV66	Filler Hose	16.	HGV80	9/16" Lockwasher
5.	HGV67	Brush	17.	HGV81	9/16" Nut
6.	HGV68	Pump Mount Bracket	18.	ST33	Angle
7.	HGV69	Brush Bracket	19.	BFR120	3/8" Union Adapter
8.	HGV70	Bracket Mount	20.	WM146	Male-Female Pipe Tee
9.	HGV71	Oiler Tube 5/32" (50')	21.	HGV82	Complete Pump
10.	HGV72	Small Tube Holder	*	HGV83	Pump Repair Kit
11.	HGV73	3/16" x 3/8" Tap Tight	22.	HGV84	Manifold Assembly (Complete)
12.	HGV74	2" Hose Clamp	23.	HGV85	Sleeve Nut
13.	HGV75	1" Hose Clamp	24.	HGV86	Standoff
*	HGV76	Medium Tube Holder	25.	HGV87	Ferrule
			*	HGV62	Complete Oiler Kit

NOTE: \* (MEANS NOT SHOWN)

FIGURE 16

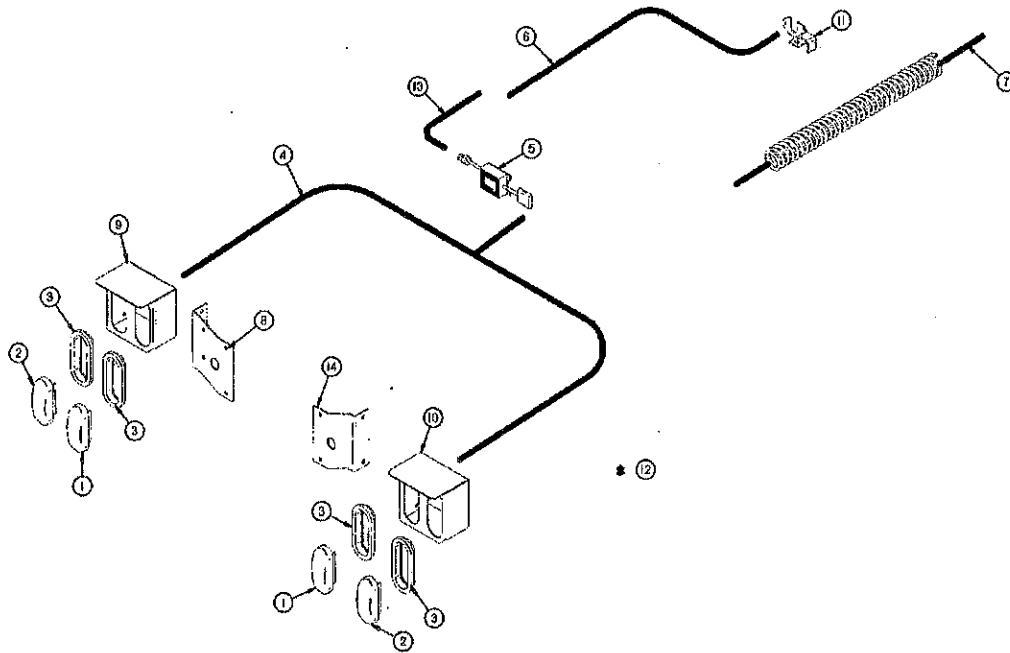

FIGURE 16  
H&S HP425 & HP550 SPRADERS  
OPTIONAL LIGHTING

ITEM	HP425	HP550	DESCRIPTION
1.	S310	"	Red Tail Light
2.	S309	"	Yellow Hazard Light
3.	S308	"	Rubber Light Mount
4.	56N155	"	Tail Light Loom
5.	S441	"	Light Module
6.	56N154	"	Flasher Module Loom
7.	S317	"	Tractor Cord
8.	55N60	"	Light Bracket Mount Left
9.	55N61	"	Light Bracket Left
10.	55N62	"	Light Bracket Right
11.	55N63	"	Light Plug Bracket
12.	55N64	"	Metal Cushioned Cable Clamps
13.	BFR666	"	Extension Light Harness
14.	55N80	"	Light Bracket Mount Right

NOTE: " (MEANS SAME AS PREVIOUS PART NO.)



FIGURE 17

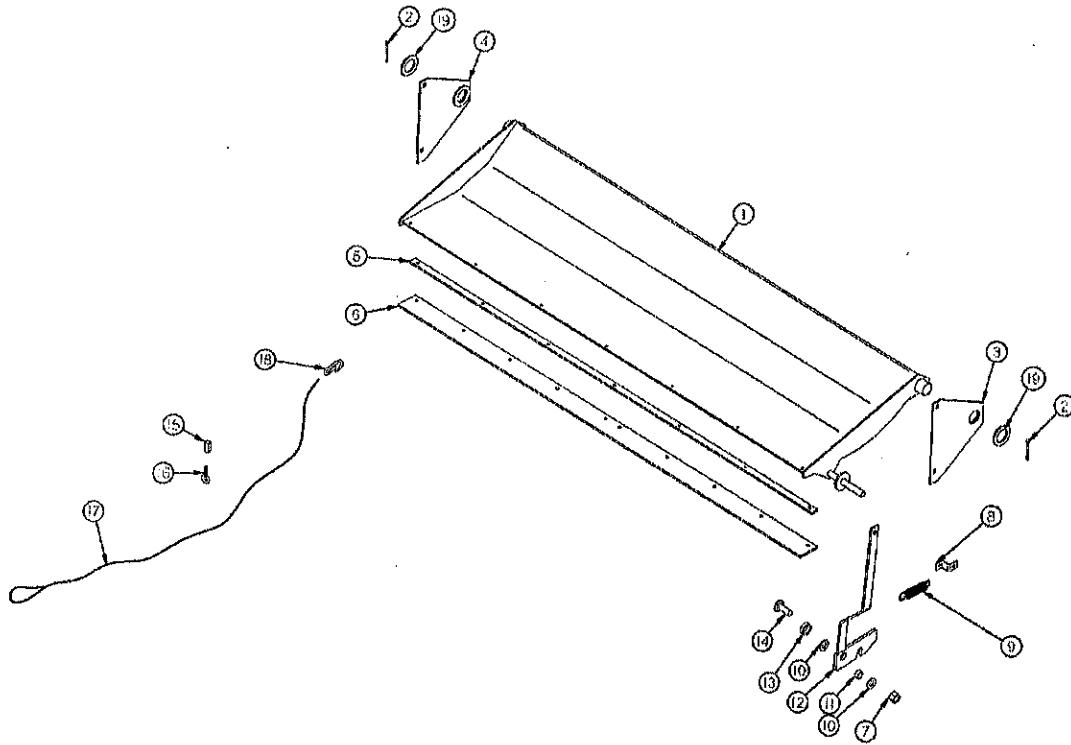

FIGURE 17  
H&S HP425 & HP550 SPREADERS  
OPTIONAL REAR PAN

ITEM	HP425	HP550	DESCRIPTION
1.	42N127	"	Pan
2.	R70	"	3/16" x 2" Cotter Pin
3.	42N128	"	Pan Plate Left
4.	42N129	"	Pan Plate Right
5.	42N130	"	Pan Strap
6.	42N131	"	Rubber
7.	HE7	"	3/4" Lock Nut
8.	F69	"	Bracket
9.	ST36	"	Spring
10.	T73	"	Washer
11.	42N132	"	Latch Bushing
12.	42N133	"	Latch
13.	42N134	"	Latch Spacer
14.	42N135	"	3/4" x 2-1/2" Carriage Bolt GR. 5
15.	23N212	"	3/8" Long Nut
16.	23N213	"	3/8" x 1" I-Bolt
17.	42N136	"	Rope (18')
18.	BFR295	"	Snap Hook
19.	56N170	"	Pan Washer

NOTE: " (MEANS SAME AS PREVIOUS PART NO.)

